

**MCx-xxxAx-8.09****Contents**

Installation	pg1-3
Mounting	pg1
Wiring	pg2
Connecting Power and Signal	pg2-3
Operation	pg4-6
DIP Switch settings	pg4
Controlling the Actuator	pg4
Torque Settings	pg5
Signal loss and Calibration	pg5-6
Troubleshooting	pg6
Appendix	pg7-9
Changing number of turns	pg7
Speed and Torque Details	pg7-8
Dimensions	pg9
Installing a cable	pg9
Factory Presets	pg10

**Installation****Mounting:**

Usually, the actuator has to be mounted and supported as shown in the picture to the left. Exceptionally, and only if the application is vibration free and the tubing is minimum 1/4" dia. stainless, the actuator may be suspended on the tubing itself.

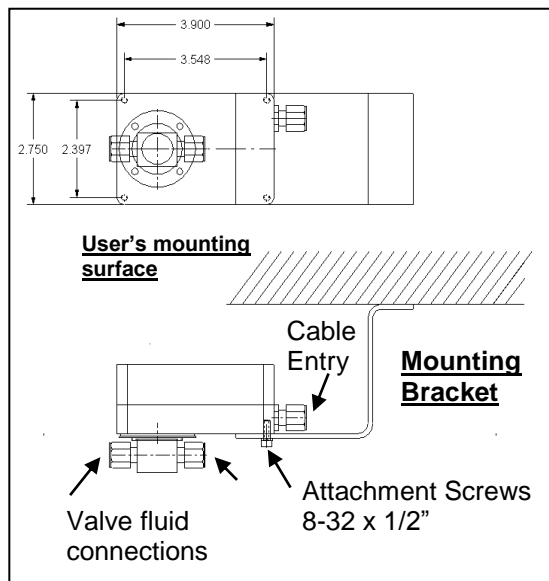

**Wiring:**

The actuator comes standard with a Turck 5 position connector and a 20' cable with plug. Cut the cable to the length required and then connect according to the following wire color schematic:



**Wire color schematic for “Turck6” cable:**

Pin	Colour	Function
6	White ->	+24VDC
5	Black ->	Power Gnd
4	Grey ->	Output Signal (4..20mA)*
3		Not connected
2	Brown->	Isolated** Input Signal Gnd
1	Blue ->	Isolated** Input + Signal (4..20mA)

\* “feedback” available in MCx-xxxAF version of actuator only

\*\* “isolated” available in MCx-xxxAI and xxxAF versions of actuator only

Otherwise, if the Turck cable is not included in your actuator, see pg.8 for more detailed wiring instructions.

**Connect the power:**

The MCx may be connected to voltages ranging from: 12 – 24 VDC.

The power consumption will range from max. 3.0A to approx min. 100mA when the actuator is active. When not moving, the actuator draws around 50mA.

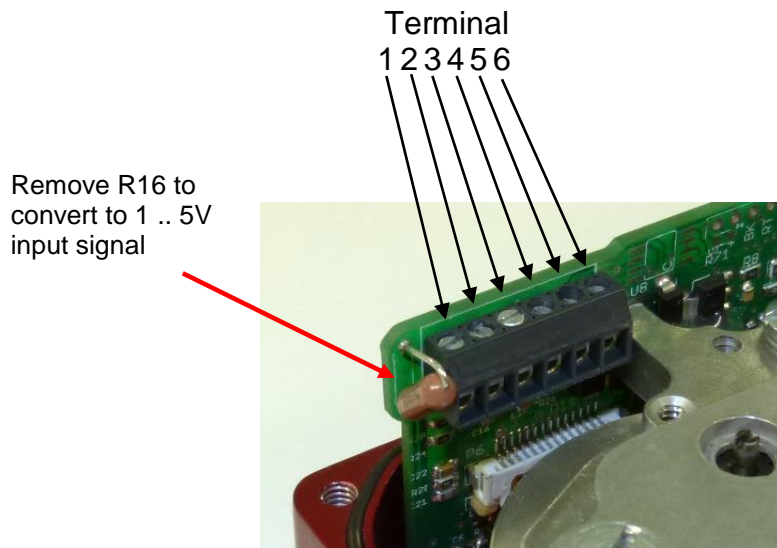
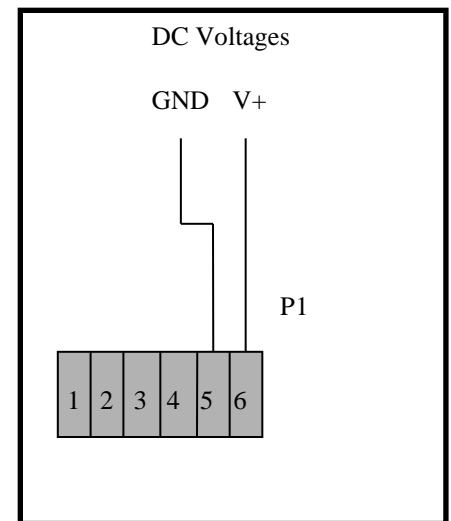

### Connect the signal:

Locate the correct connection terminals as shown on the previous page, then connect your input signal on pos. 1 and 2 as shown below. Feedback, if applicable, is connected to pos. 3.

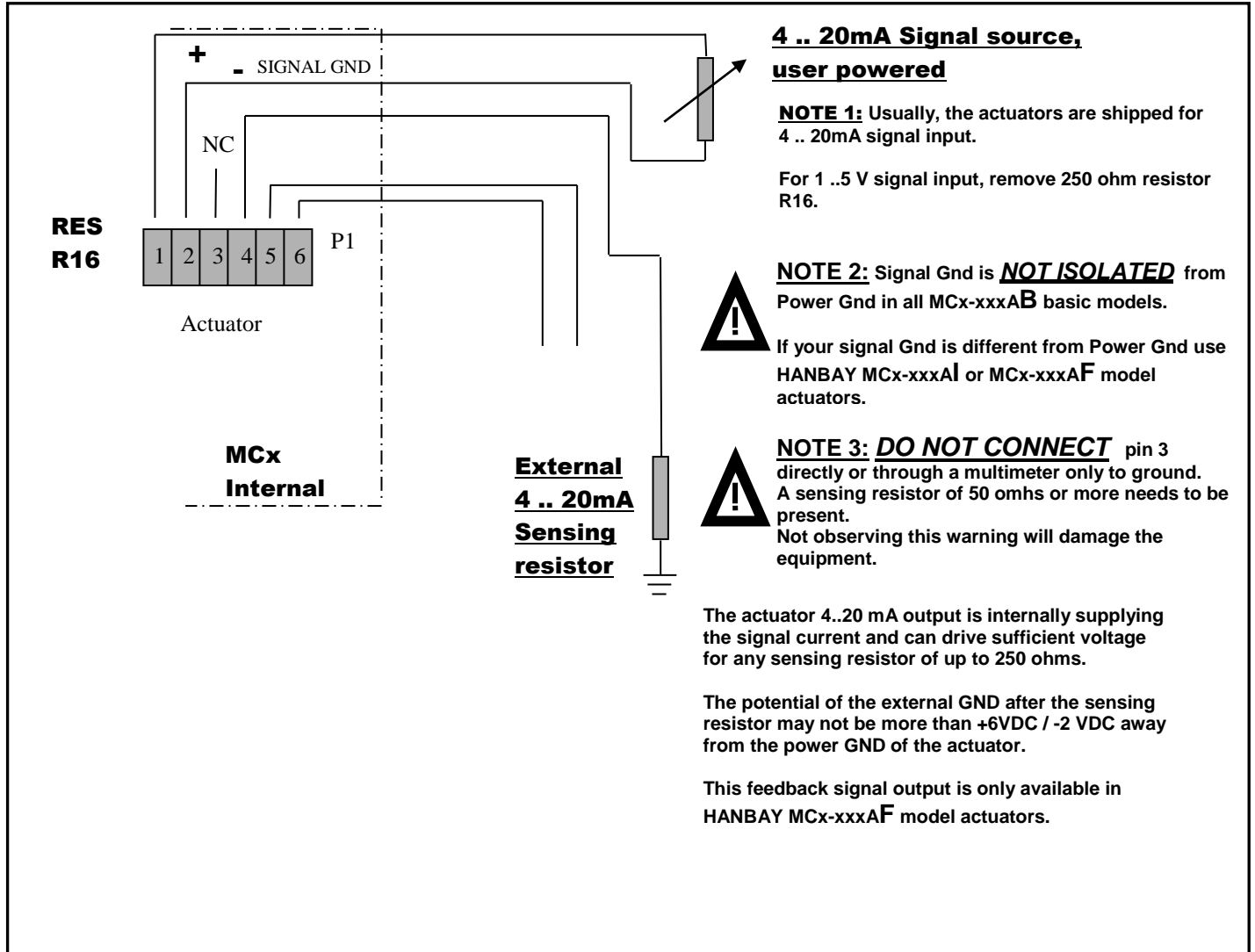

## Operation

### DIP switches:

The DIP switches allow you to change the settings on your actuator. To flip a switch, gently use a small flat-head screwdriver. See chart on next page for DIP switch functionality.

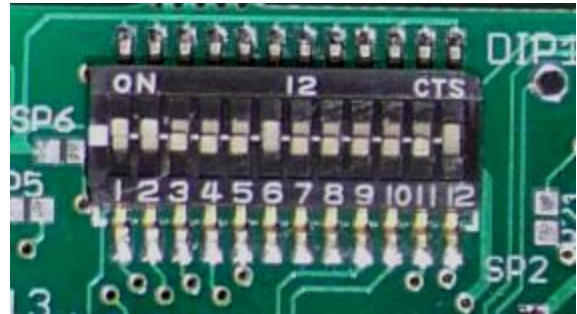

In this example DIPs 1, 2, 6 and 12 are on.

DIP	Function
1 2	Speed: Choose how quickly the actuator will turn the drive wheel. See pg 6-7.
3 4 5 6 7 8	Turns: The actuator usually ships from the factory with the recommended number of turns for the valve. This number can be changed however. See pg 6 for relation between position of the dip switches vs. number of turns. Turning on a switch will add that number of turns to the actuators movement. Example: Turning on DIP 6 will add four turns, turning on DIP 8 adds one turn. If both DIP 6 and 8 are on, then the total turns of the actuator is five.
9	Signal loss: See below.
10 11	Power: Set how much torque the actuator exerts on the valve lever. See below and pg 6-7.
12	Direction/Calibration: Toggle switch on and off while powered to re-calibrate actuator. Also sets direction in which the actuator will open and close. See pg 5.  Example: The MCM model actuator turns clockwise when the signal is decreased with DIP 12 in the OFF position. For changes to rotation to take affect flip the switch and cycle the power to the actuator.

### Controlling the Actuator:

The 4 .. 20mA (or 1.. 5V) input signal represents a total span of a number of turns.

I.e.: If you set the number of turns to 2, then a signal of 12mA will set the actuator to exactly 1 turn from the fully closed position. 15 mA will give:  $(15-4)/16=0.6875 \Rightarrow 68.75\%$  of 2 turns  $\Rightarrow 1.375$  turns from closed etc.

With the dip switch settings, you can adjust anything between 1 and 64 turns to represent the full signal range of 4 .. 20mA. Check in the table below. (1 = "On" 0 = "Off")

## Torque Settings:

To accommodate different valves and other applications with different torque requirements, the actuator can be set to apply different torque on the valve stem. Please see the box to the right and the tables on pg 7-8 to select the power setting that is right for your application. The actuator will try to reach the speed set by Dip1 and Dip2. If the torque required is too high, the actuator will automatically slow down and deliver the maximum available torque for a given "Permanent Power Setting".

### Permanent power settings: (when operating at 24V)

Dip10	Dip11	Power
Off	Off	16%
Off	On	33%
On	Off	66%
On	On	100%

To deal with sticking valves, at the beginning of the first reversing movement after the seating ("zeroing") of the valve, the actuator will apply double the power set by Dip10 and Dip11 (up to 100% power.) This "pull out" function is always enabled.



**Warning:** High power settings can supply enough torque to damage your valve. Please be cautious, especially when using the 100% power setting.

## Signal Loss and Calibration:

1. - **For actuators that are not connected to a UPS** (Uninterruptible Power Supply), the loss of signal will be simultaneous with power loss. As a consequence, the actuator will not be able to move anywhere. In the shutdown process though, the actual position is automatically saved to the internal EEPROM. [this saving of the position is only happening for min. 18VDC supplies]

When power is restored, the actuator will "know" its location and will simply start to follow the signal as received.



**IF YOU HAVE TO** turn the actuator manually when its power is turned off, it will lose its position, and it will need to be re – zeroed (as described in section 3 on the following page).

2. - **For actuators that are connected to a UPS** the behavior on signal loss can be set as follows:

### Normal position of DIP9: OFF

With DIP9 in the off position, the actuator will ignore the signal if it is lost (I.E.: if the signal falls below 0.7V) and simply remain in its current position.

**Note:** if the sensing resistor R16 is removed (for 1..5V input signals), we recommend placing a 10K resistor between signal and signal GND.

### Predetermined signal loss position DIP9: ON

With DIP9 in the on position, the actuator will move to a predetermined position when the signal is lost (I.E.: if the signal falls below 0.7V).

Setting of the predetermined signal loss position:

- a. - turn Dip9 to the "off" position
- b.- re – zero the actuator by sending and holding an input signal between 2.8 and 4.16 mA (0.7 to 1.04V) wait until the device is re-zeroed, (i.e: the valve is closed)
- c. - by varying the input signal, move the actuator to the position that is going to be the predetermined signal loss position.

- d. - switch Dip9 to the “on” position. The current actuator position will be saved as the default signal loss position. (The default signal position is an absolute actuator position. I.e.: not a signal value.)
3. - **Re – Zeroing the actuator and initiating calibration routine:**

The actuator will re-zero when the input signal is between 2.8 and 4.16mA (0.700V – 1.040V). It will turn clockwise until the actuator has reached the fully closed position of the valve.

**Different valves mounted to actuator need the calibration routine initiated manually.** This is done by toggling dip switch 12 in the one way and back to its original position while the actuator is powered. This will initiate the calibration routine and is essential when changes have been made to the valve.

**If you need to re-zero in the opposite direction** (i.e: for pressure regulators, which typically go to the “top” fully open position at 4mA) change the setting of Dip switch DIP12 and cycle power.
  4. - **Feedback calibration: [MCx-xxxAF model actuators only]**

The current feedback will be calibrated from the factory.  
To re-calibrate the feedback:

    - a.- turn off the actuator, and disconnect the feedback and input signals
    - b.- connect the feedback signal to the signal input. Also connect the power and signal grounds.
    - c.- power up the actuator with this “signal back-loop” setup.
    - d.- Short SP5. It will automatically run a special routine to calibrate the feedback signal to the signal input.  
The whole process takes about 1.5 seconds.
    - e.- turn off the power and reconnect the actuator as normal.

## Troubleshooting:

Upon noticing a problem, your first step should almost always be to recalibrate the actuator by switching DIP 12, then switching it back to its original position, all while the actuator is powered. This alone can solve basic problems. See section 3 on this page for more details.

### **If the actuator does not move, try following these steps:**

- 1) Re-calibrate the actuator. This will move the actuator regardless of what signal it is receiving.
- 2) A sticking valve may be the problem. Remove the valve from the actuator, and re-test the actuator.
- 3) Remove power. Re-check the wiring and the power/signal apparatus. Power actuator, and re-calibrate. If the problem persists, please call Hanbay for technical support.

## Appendix

### Changing the number of turns:

The 4 .. 20mA (or 1.. 5V) input signal represents a total span of a number of turns.

I.e.: If you set the number of turns to 2, then a signal of 12mA will set the actuator to exactly 1 turn from the fully closed position. 15 mA will give:  $(15-4)/16=0.6875 \Rightarrow 68.75\%$  of 2 turns  $\Rightarrow 1.375$  turns from closed etc.

With the dip switch settings, you can adjust anything between 1 and 64 turns to represent the full signal range of 4 .. 20mA. Check in the table below. (1 = "On" 0 = "Off")

Total Turns Dip4=0	Dip5	Dip6	Dip7	Dip8
reserved	0	0	0	0
1	0	0	0	1
2	0	0	1	0
3	0	0	1	1
4	0	1	0	0
5	0	1	0	1
6	0	1	1	0
7	0	1	1	1
8	1	0	0	0
9	1	0	0	1
10	1	0	1	0
11	1	0	1	1
12	1	1	0	0
13	1	1	0	1
14	1	1	1	0
15	1	1	1	1

For more turns set Dip3 and Dip 4 as follows:

	Dip3=0	Dip3=1
Dip4=0	0	+32turns
Dip4=1	+16 turns	+48turns

Note:

This actuator can accommodate up to the following number of turns on its different models:

MCL -xxxAx	63 turns	MCJ -xxxAx	63 turns
MCM- xxxAx	63 turns	MCK -xxxAx	63 turns
MCH- xxxAx	29 turns		

**WARNING:** Be sure that the number of turns the actuator is set for is LESS than the number of turns for the valve. The actuator should not stop itself on a fully opened valve. It can damage the valve, and the actuator will lose its position.

### Speed and Torque Details:

The maximum speed of the actuator can be set by using the first two positions of the **DIP switch selector**.

As a result of this setting, the actuator will limit the maximum speed. The tables below show the maximum torques that can be expected at the given maximum speeds.

The torque available also depends on the voltage provided in the power connection and on the Permanent power settings on DIP 10, 11 as shown below. \*

Speed and Torque of MCL-xxxAx Actuators

**NOTE:** If actuator is MCJ-xxxAx, divide torque values by 3.

Dip1	Dip2	Time for 1 turn (sec)	Torque in in-lbs		Torque in in-lbs		Torque in in-lbs		Torque in in-lbs	
			16% Power*		33% Power*		66% Power*		100% Power*	
			12VDC	24VDC	12VDC	24VDC	12VDC	24VDC	12VDC	24VDC
OFF	OFF	5	2	5	5	11	9	21	14	32
OFF	ON	4	2	5	4	9	7	19	11	28
ON	OFF	3	1	4	2	8	5	16	8	25
ON	ON	1	N/A	4	N/A	8	N/A	15	N/A	23

To convert in-lbs to Nm, divide the in-lbs value by 9

Speed and Torque of MCM-xxxAx Actuators **NOTE:** If actuator is MCK-xxxAx, divide torque values by 3.

Dip1	Dip2	Time for 1 turn (sec)	Torque in in-lbs 16% Power*		Torque in in-lbs 33% Power*		Torque in in-lbs 66% Power*		Torque in in-lbs 100% Power*	
			12VDC	24VDC	12VDC	24VDC	12VDC	24VDC	12VDC	24VDC
OFF	OFF	16	6	15	13	30	27	60	40	90
OFF	ON	12	5	13	11	27	21	53	32	80
ON	OFF	8	4	12	7	23	15	47	22	70
ON	ON	4	N/A	11	N/A	22	N/A	43	N/A	65

To convert in-lbs to Nm, divide the in-lbs value by 9

Speed and Torque of MCH-xxxAx Actuators

Dip1	Dip2	Time for 1 turn (sec)	Torque in in-lbs 16% Power*		Torque in in-lbs 33% Power*		Torque in in-lbs 66% Power*		Torque in in-lbs 100% Power*	
			12VDC	24VDC	12VDC	24VDC	12VDC	24VDC	12VDC	24VDC
OFF	OFF	60	22	51	44	101	91	203	135	304
OFF	ON	45	17	44	37	91	71	179	108	270
ON	OFF	30	14	41	24	78	51	159	74	236
ON	ON	15	N/A	37	N/A	74	N/A	145	N/A	219

To convert in-lbs to Nm, divide the in-lbs value by 9

N/A in these tables means:

The actuator will not be able to reach the requested speed for this combination of power / voltage / speed settings. It will always run slower to be able to overcome the internal torque requirements. So these points can be set but the expected end speeds would not be reached.

**Note: 66% setting and 100% setting require voltage supply minimum values as follows:**



- Supply voltage needs to be min 14 VDC for 66% setting
- Supply voltage needs to be 16 VDC for 100% setting
- When operating above 20VDC and 66% power, Duty cycle is reduced to 50% - 25% maximum. At these levels, the electronics produce more heat which must be dissipated (depending on environmental temperature)



**Note: Digital potentiometer functionality is disabled for supply voltages below 18VDC, so the actuator position will not be retained on power-loss, on power-up the actuator will need to be re-zeroed every time.**





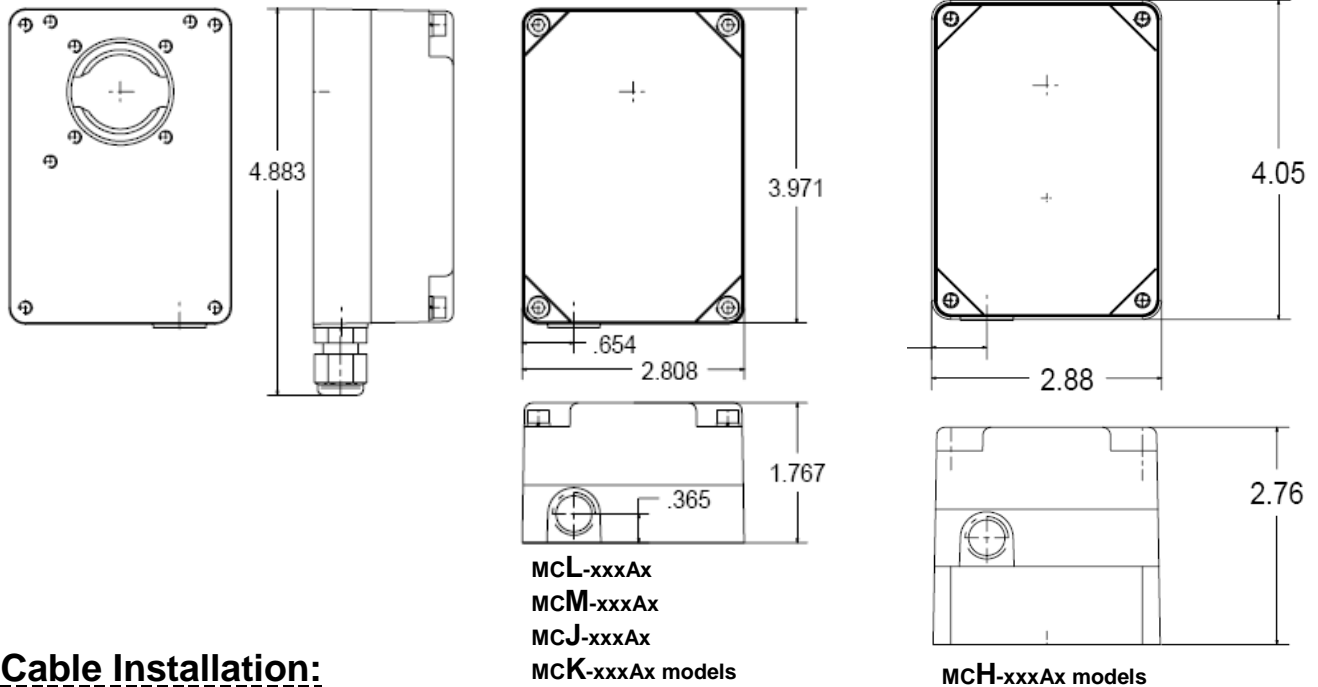



**Main Dimensions:**



**Cable Installation:**

Select a connection cable with 5 leads.

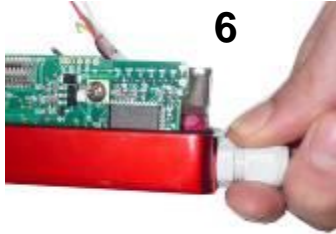
The liquid tight strain relief on the base of the actuator is designed to accommodate a cable of **O.D. 2.5 - 6.5mm (0.10 - 0.26in)**. Be sure to not use a cable with an OD that is no bigger than this!

1.  1.- Remove the liquid tight fitting from the actuator casing and insert the cable into it.
2.  2.- The cable has to be stripped of its jacket for 2 inches (50mm) and the wires need 1/8" (3mm) stripped ends.
3.  3.- Bend the wires so that insertion becomes easy.
4.  4.- Carefully insert the cable into the actuator base. Mind the red motor cable and its plug into the board. Moving the plug out of its fully inserted position may cause malfunction of the actuator.
5.  5.- Put the liquid tight fitting back and tighten (lightly with tool).
6.  6.- Hand tighten the liquid tight fitting to establish seal.
7.  7.- Connect wires according to your application (see page 2,3).
8.  8.- Mount actuator cover and tighten 4 screws.

# Factory Presetting

Invoice No:  
Line item :

Full Hanbay Part Number: M C -    A -    -  

Hanbay Electronics: A          

Hanbay Firmware: A            

Valve Manufacturer:

Valve Number of turns:

**Valve Type:**

- Needle Valve
- Globe Valve
- Ball Valve
- Other (specify)

The Dipswitch settings we applied to your actuator are: (1="On", 0="Off")

Dip1	Dip2	Dip3	Dip4	Dip5	Dip6	Dip7	Dip8	Dip9	Dip10	Dip11	Dip12

**Notes & recommendations:**

FIRMWARE SETTINGS	
MCL	
FULL_RES	0
LOW_TORQUE	0
MULTI_TURN	1
MULTI_TURN_EX_GEARSTAGE	0
DEG_90	0
DEG_97	0
DEG_90_EX_GEARSTAGE	0
DEG_97_EX_GEARSTAGE	0
MIN_MOVE	2
MIN_CHANGE_MOVE	8
P_GAIN	9
D_GAIN	25
DECEL_REGION	150
MAX_FULL_SPEED	30
MAX_STALL_PERIOD	6
TH_TO_DECEREASE_RESOLUTION	24

M     -            -    -

**MODEL NUMBER**

↓ Valve Manufacturers Valve Part Number/CU Number

- 0 No Valve or Mounting Kits
- 1 Mounting Kits Only
- 3 Valve with Mounting Kits, Mounted Assembly
- 4 Swagelok Bracket, Mounting Kits
- 5 Swagelok Bracket, Valve with Mounting Kits, Mounted Assembly
- 6 Drive lever only
- 7 External Stop

- AB Analog Signal Board Base Model
- AI Analog Signal Board Isolated Model
- AF Analog Signal Board Isolated with Feedback
- DC Continuous TTL Input Board
- DT TTL Input Board
- SB Serial-Analog Signal Board Base Model
- SI Serial-Analog Signal Board Isolated Model
- 0 Nothing Special
- 5 Remote Control Potentiometer
- 6 Remote Control Selector Switch
- H Heater
- 0 Nothing Special
- 5 TURCK 5 Position Connector w. 20' Cable and Plug
- 6 TURCK 6 Position Connector w. 20' Cable and Plug
- 7 TURCK 5 Position Connector only
- 8 TURCK 6 Position Connector only
- 0 Nothing Special
- B Explosion proof B
- C Explosion proof C
- X Custom [see CU Number]
- M Manual Override
- P Position Indication
- S Stainless Housing SS316
- L Low J – Low Power Motor
- M Med K – Low Power Motor
- H High D – Low Linear
- U Ultra High E – Med Linear

- DF Continuous TTL Input Analog Feedback
- EF Continuous 24V TTL Input Analog Feedback
- ET 24V TTL Input Board

- ↓ D Discrete
- ↓ C Continuous

**M – BLDC Miniature Actuator**